

HP Integrity rx8640 Server System Overview-Front View

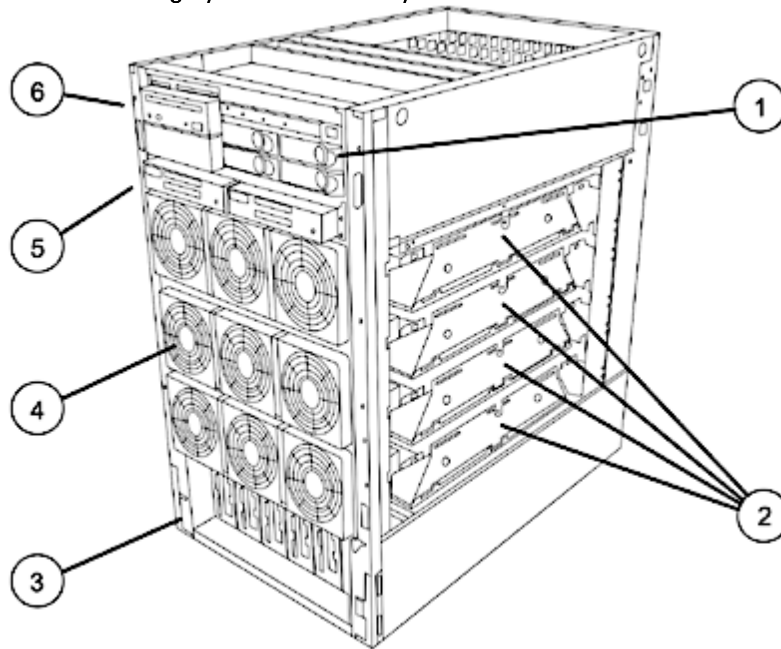

- | | |
|-----------------------------|------------------------------|
| 1. Hot plug disks | 4. Redundant hot-swap fans |
| 2. Cell boards | 5. PCI power supplies |
| 3. Redundant hot-swap power | 6. Removable media - DVD/DAT |

Integrity rx8640 Server System Overview-Rear View

Overview

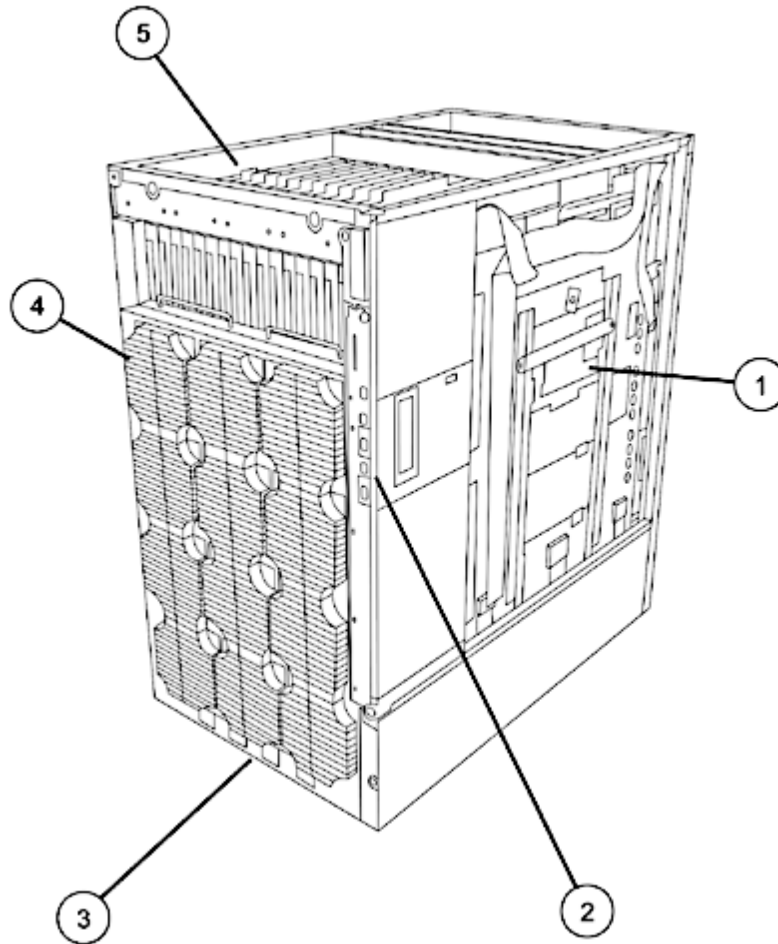

- 1. System backbone
- 2. Core I/O
- 3. 2N redundant power inputs

- 4. Hot-swap redundant fans
- 5. Hot-plug PCI slots

At A Glance

rx8640 Server Product Number (base)

AB297A

Standard System Features

Overview

- HP UX 11i v2 operating system
- Microsoft Windows Server 2003 Datacenter and Windows Server 2003 Enterprise Edition
- Linux (future)
- OpenVMS (future)
- External Ultra320 SCSI channel
- Two Internal Ultra320 SCSI channels, one channel to each internal disk
- 1 GbE LAN ports
- Management Processor technology with Integrated LAN console
- Rackmountable into 19 inch cabinets (factory or field integration)
- Rackmountable into some 3rd party cabinets
- Two hardware partitions (nPartitions)
- Four hardware partitions when configured with the Server Expansion Unit
- Factory integration of processors, memory, disk drives, removable media drives, and I/O cards
- site planning and installation
- One year warranty with same business day on site service response
- Owner's Guide and General Usage media set

HP Integrity rx8640 Server Flexible Advantage Starter (FAST) Base Systems

The Flexible Advantage **ST**arter base systems for the HP Integrity rx8640 Server allow for faster configurations due to the semi configured base system bundles. Configurations built from FAST base systems will have substantially lower prices than systems built from the parts.

HP Integrity rx8640 Server FAST bundles

Product Number (Includes base chassis and power supplies)	Number of Intel Itanium 2 1.6 GHz processors	Number of Cell Boards	Number of Core I/O Cards	Number of Power Supplies
AD065A	2	1	1	3
AB442A	4	1	1	3
AB443A	8	2	1	4
AB444A	16	4	1	6

Standard Features

Minimum System

- Two Intel Itanium 2 Madison 1.6 GHz 6 MB L3 cache
- One processor/memory cell board
- 2 GB memory (1 pair)
- One core I/O
- Two power cords
- 8 hot plug 33-/66-/133-/266-MHz 64 bit PCI X slots with adaptive signaling technology

Maximum Server Capacities

- Sixteen Intel Itanium 2 Madison 1.6 GHz 6 MB cache processors
- Four processor/memory cell boards
- 128 GB memory (32 pairs)
- Two core I/O
- Four power cords, providing 2N power and dual-grid support
- Four internal hot plug LVD SCSI disks
- Two removable media drives-DVD or DAT
- Sixteen PCI expansion cards

Maximum capacities when configured with the Server Expansion Unit 2 (SEU-2):

- Four core I/O cards
- Eight internal hot plug LVD SCSI disks
- Four removable media drives-DVD or DAT
- 32 hot plug 33-/66-/133-/266-MHz 64 bit PCI X slots with adaptive signaling technology

Standard System Features

- HP UX 11i v2 operating system
- Microsoft Windows Server 2003 Datacenter and Windows Server 2003 Enterprise Edition
- Linux (future)
- OpenVMS (future)
- External Ultra320 SCSI channel
- Two Internal Ultra320 SCSI channels, one channel to each internal disk
- 1 GbE LAN ports
- Management Processor technology with Integrated LAN console
- Rackmountable into 19 inch cabinets (factory or field integration)
- Rackmountable into some 3rd party cabinets
- Two hardware partitions (nPartitions)
- Four hardware partitions when configured with the Server Expansion Unit
- Factory integration of processors, memory, disk drives, removable media drives, and I/O cards
- site planning and installation
- One year warranty with same business day on site service response
- Owner's Guide and General Usage media set

Standard Features

High Availability

- N+1 Hot swap cooling
- Redundant and hot swap power supplies
- Cell Hot plug
- Hot plug disks
- 2N power inputs
- On line memory page deallocation
- ECC protected DDR-II memory
- Full parity protection of data and address buses
- On chip processor cache with ECC protection
- Memory "chip spare", "chip kill" like
- Dynamic Processor resilience and deallocation (processor deallocation on failure)
- On line addition and replacement of PCI I/O cards
- UPS power management
- Four independent UltraSCSI buses to internal disks for mirroring across disks and controllers
- Journal file system
- Auto reboot
- On line diagnostics and system health monitor
- Microsoft Cluster Services for Windows Server 2003 Enterprise and Datacenter Edition
- HP StorageWorks Software for HP Integrity Servers running Windows Server 2003, Enterprise and Datacenter Editions. Includes Cluster Extension XP and EVA, Continuous Access, Business Copy and SQL Server Fast Recovery

Security

- Separate console LAN port for system management
- Password protection on console port
- Disablement of remote console ports

Internet Server Functions

- Internet server (inetd)
- Domain name server
- Routing (OSPF, BIND, RIP, EGP, HELLO, gateD)
- Network Time Protocol

Client Configuration Services

- Automatic configuration for printers, PCs, workstations, and X terminals (DHCP, Bootp, tftp, rbootp)

Optional Web Services

- Netscape Communication Server
- Netscape Navigator

Email

- Mail, MailX, ELM
- Sendmail, MIME, SMTP, ESMTMP

Remote Access Services

- Telnet, ftp, anonymous ftp server

Configuration

Configuration The HP Integrity rx8640 Server is a symmetrical multiprocessing (SMP) server supporting up to 16 high performance Intel Itanium 2 1.6 GHz 6 MB L3 cache. The server supports the new and improved sx2000 chip set. The rx8640 can be configured as a single SMP server or divided into up to four smaller, hardware partitioned (nPars), logical servers.

Cell Boards A minimum of one and a maximum of four cells can be ordered in HP Integrity rx8640 Servers. Each cell can be purchased with up to four active Intel Itanium 2 processors or in combination with Instant Capacity processors. One processor speed is supported for the Intel Itanium 2 processor at 1.6 GHz.

The HP Integrity rx8640 and HP Integrity rx7640 (8-processor) servers share the same cell board.

Cell Details

- 4 processor module slots (supporting up to eight processors in future)
- sx2000 cell controller
- 16 DDR-2 Memory DIMM slots
- DC DC Power converters
- Manageability and Processor Dependent Hardware Circuitry

Cell Board Configuration Rules

- Cell boards are ordered individually
- Minimum: 1 cell board; Maximum: 4 cell boards
- Cell slots 0 or 1 must be loaded first
- Recommended Cell board loading order: 0,1,2,3

Intel Itanium 2 Details

- 1.6 GHz
- Level 3 Cache: 6 MB
- Level 2 Cache: 256 KB
- Level 1 Cache: 32 KB
- Single bit cache error correction
- 44 bit physical addressing
- 64 bit virtual addressing
- 4 GB maximum page size

Processor and Module Configuration Rules

- 1.6-GHz processors consist of two chips (two processors) and can only be ordered or upgraded in pairs (two processors)
- There must be at least two processors active (non Instant Capacity) on each cell board.
- On each cell board, processors or modules must be installed in the following sequence 0, 2, 1, 3

Memory Configuration The memory DIMMs used in the HP Integrity rx8640 Server are sold in pairs and are custom designed by HP. Each DIMM contains DDR-II memory chips qualified to run at 267/533 MHz, with full ECC protection. DIMM sizes of 1 GB and 2 GB are supported. 9000 rp8400/rp8420/rx8620 memory modules cannot be carried forward to the rx8640 server. Each HP Integrity rx8640 Server cell board supports up to 16 DIMM slots and 17 GB/s of peak memory bandwidth.

HP Integrity rx8640 Memory DIMMs

Configuration

Pair Size (Product)	rx8640 Product Number	HP Integrity rx8640 Server Maximum Capacity Using 1 DIMM Size	DIMM Size
2 GB	AB453A	64 GB	1024 MB
4 GB	AB454A	128 GB	2048 MB

Memory Loading Rules

- Memory must be installed in pairs (2 DIMMs of equal density)
- DIMM pairs must be loaded in slot order
- Memory is available in two densities: 2 GB (2×1024MB) and 4 GB (2×2048MB)
- Minimum memory is 2 GB per cell
- Maximum memory per system is 128 GB-using thirty two 2 GB pairs per system
- Larger DIMMs must be loaded first across a cell, followed by progressively smaller DIMM sizes.
- On each cell board, Memory pairs must be installed in the following order: (0A, 0B), (1A, 1B), (2A, 2B), (3A, 3B), (4A, 4B), (5A, 5B), (6A, 6B), (7A, 7B)
- DIMM mixing other than recommended configurations is supported as long as the memory loading rules are followed

rx8640 Recommended Memory Configurations

Desired Memory per Cell (GBs)	Number of DIMMs		Cell Loading DIMM Slots							
	1 GB	2 GB	0A, 0B	1A, 1B	2A, 2B	3A, 3B	4A, 4B	5A, 5B	6A, 6B	7A, 7B
2	2		1 GB							
4	4		1 GB	1 GB						
8	6		1 GB	1 GB	1 GB	1 GB				
16	16		1 GB	1 GB	1 GB	1 GB	1 GB	1 GB	1 GB	1 GB
24	8	8	2 GB	2 GB	2 GB	2 GB	1 GB	1 GB	1 GB	1 GB
32		16	2 GB	2 GB	2 GB	2 GB	2 GB	2 GB	2 GB	2 GB

Performance Tuning Guidelines

- For best performance, a cell should be configured with a multiple of 8 DIMMs or four pairs (although the server will execute properly with an odd number of pairs). It takes 8 DIMMs to populate both memory buses. Populating only one of the two memory buses on a cell board will deliver only half the peak memory bandwidth.
- Load memory equally across the available cell boards.
- If growth is planned for the system, then plan on configuring high density 4 GB modules (2GB memory pairs) to minimize memory slot constraints.

Memory Latencies

There are two types of memory latencies within the HP Integrity rx8640 Server:

1. Memory latency within the cell refers to the case where an application either runs on a partition that consists of a single cell or uses cell local memory.
2. Memory latency between cell refers to the case where the partition consists of two or more cell and cell interleaved memory is used. For example, for an rx8640 server with four cells in the partition, 25% of the addresses are to memory on the same cell as the requesting processor, and the other 75% of the addresses are to memory on the other three cells.

The HP Integrity rx8640 Server memory latency depends on the number of processors in the partition. Assuming that memory accesses are equally distributed across all cell boards and memory controllers within the partition, the average idle memory latency (load to use) is as shown below:

Configuration

Number of processors	Average Memory Latency
4-processor	185 ns
8-processor	249 ns
16-processor	334 ns

I/O Architecture

Components within the I/O subsystem are the I/O controllers, internal peripheral bay, and multifunction Core I/O. The figure below shows the basic block diagram of the I/O subsystem. The Integrity I/O architecture utilizes industry standard PCI buses in a unique design for maximum performance, scalability and reliability.

The HP Integrity rx8640 Server contains two master I/O controller chips located on the PCI X backplane. Each I/O controller contains sixteen high performance 12 bit wide links, which connect to sixteen slave I/O controller chips supporting the PCI X card slots and core I/O. Two links, one from each master controller is routed through the crossbar backplane and is dedicated to core I/O. The remaining thirty links are divided among the sixteen I/O card slots. This one card per link architecture leads to greater I/O performance and higher availability. Each controller chip is also directly linked to a host cell board. This means that at least two cell boards, located in cell slots 0 and 1, must be purchased in order to access all sixteen I/O card slots. With one cell board, access to eight slots is enabled.

The HP Integrity rx8640 Server can be purchased with either one or two core I/O boards (if an SEU is added, then 4 core I/O boards with 2 core I/O in the SEU). Both core I/O boards are identical and provide console, SCSI, serial, and Management Processor (MP) functionality. The second core is used to enable the dual hard partitioning in the HP Integrity rx8640 Server and provide access to a second set of disk drives. The second I/O controller in the host server is optional and is not required to support all 4 cell boards.

The internal peripheral bay is divided into two identical halves. Each half supports up to two low profile disks and one removable media device. A SCSI controller chip located on each core I/O board supports each half of the internal peripheral bay. This means that both core I/O boards must be purchased to access both halves of the peripheral bay.

PCI Backplane

Eight of sixteen I/O card slots are supported by dual high performance fat links. Each link is capable of providing 1060 MB/s of bandwidth. This means that half HP Integrity rx8640 Server I/O slots are capable of sustained 2.12 GB/s. Six of the sixteen I/O card slots are supported at 1060 MB/s of bandwidth. Aggregate I/O slot bandwidth is approximately 23 GB/s. In addition, because each I/O slot has a dedicated bus, any slot can be "hot plugged" or serviced without affecting other slots. The hot plug operation is very easy, and can be done with minimal training and effort.

The HP Integrity rx8640 Server supports a number of PCI and PCI X HBA (I/O) cards for I/O expansion (see the **Supported HP-UX I/O Cards table** for HP-UX servers and the **Supported Windows 2003 I/O Cards table** for Windows 2003 servers). **NOTE: The PCI-X backplane is backward compatible with the older PCI backplane and can support many PCI HBA (I/O) cards.**

When 9000 rp8400 servers are upgraded to HP Integrity rx8640 servers using the chassis upgrade kit, the older and slower PCI backplanes in the 9000 rp8400 server are upgraded to the newer and faster PCI X backplanes of the HP Integrity rx8640 Server.

When the rp84xx/rx86xx Server Expansion Unit 2 is connected to the HP Integrity rx8640 Server, its I/O backplanes act as PCI X I/O backplanes. See the rp84xx/rx86xx Server Expansion Unit 2 section for more details.

Configuration

Supported I/O Cards

Supported HP-UX I/O Cards

I/O Card	Product Number	First HP-UX Release/ Boot Support	Connector Type(s)	Hot Plug/ Factory Integration	Maximum Cards/Ports
Mass Storage Host Bus Adapters					
PCI 1 port 2x Fibre Channel	A5158A	11.00 / No	Duplex SC	Yes/No	16 / 16
PCI 2 Gb Fibre Channel	A6795A	11.00 / Yes	LC	Yes / Yes	16 / 16
PCI 1-port 4-Gb Fibre Channel	AB378A	11i/Yes		Yes / Yes	16 / 16
PCI 2-port 4-Gb Fibre Channel	AB379A	11i/Yes		Yes/No	16 / 16
PCI 1 channel Ultra160 SCSI	A6828A	11.00 / Yes	VHDCI	Yes/No	16 / 16
PCI 2 channel Ultra160 SCSI	A6829A	11.00 / Yes	VHDCI	Yes/No	16 / 32
Dual-channel Ultra320 SCSI Adapter	A7173A	11.i/Yes	VHDCI	Yes / Yes	16 / 32
PCI X 2 channel 2 Gb/s Fibre Channel	A6826A	11i / Yes	LC (SFF)	Yes / Yes	16 / 32
PCI X 2 channel Smart Array 6402	A9890A	11i / Yes	VHDCI	Yes / Yes	8/16
PCI X 4 channel Smart Array 6404 256 MB	A9891A	11i / Yes	VHDCI	Yes / Yes	8/32
PCI X 1 port 10 Gb Ethernet Fiber Adapter	AB287A	11iv2/Yes	Duplex SC	Yes / Yes	2/2
PCI X 4-port 1000Base T Gigabit Adapter	AB545A	11iv2/Yes	RJ 45	Yes / Yes	16/64
PCI 1 port 1000Base SX	A6847A	11.00/Yes	Duplex SC	Yes / Yes	16/16
PCI 1 port 1000Base T	A6825A	11.00/Yes	Duplex SC	Yes / Yes	16/16
PCI 1 port 1000Base SX	A4926A	11.00/No	Duplex SC	Yes/No	16/16
PCI 1 port 10/100Base T	A5230A	11.00/No	RJ 45	Yes/No	16/16
PCI 1 port 1000Base T	A4929A	11i/No	RJ 45	Yes/No	16/16
PCI 4 port 10/100Base T	A5506B	11.00/No	RJ 45	Yes/No	16/64
PCI Dual-port 1000BaseSX	A7011A	11iv2/Yes		Yes / Yes	16/32
PCI Dual-port 1000Base-T	A7012A	11iv2/Yes		Yes / Yes	16/32
PCI X 2 port 4X Fabric HCA (HPC)	AB286A	11iv2/No	4x Infiniband Copper	Yes/No	2/4
PCI X 2 port 4X Fabric HCA (HPC)	AB286B	11iv2/No	4x Infiniband Copper	Yes/No	2/4
PCI X 2 port 4X Fabric (HA and DB) Adapter	AB345A	11iv2/No	4x Infiniband Copper	Yes / Yes	16/32
Multi-Function Cards (MassStorage / LAN)					
PCI 2 port 100Base-T / 2 port Ultra2SCSI	A5838A	11.00/No	VHDCI/RJ 45	Yes/No	16 / 64
PCI X 2 Gb Fibre Channel/1000Base SX	A9782A	11i / Yes	LC (SFF) / LC GigE	Yes / Yes	16 / 32
PCI-X 2-Gb Fibre Channel, 1000Base-T	A9784A	11i / Yes	1 LC / 1 RJ-45	Yes / Yes	16 / 32
PCI-X 2-port 2Gb FC/ 2-port 1Gb Ethernet	AB465A	11v2/Yes	2 LC/2 RJ-45	Yes / Yes	16 / 64
PCI-X 2-port 1000BT/2-port U320 SCSI	AB290A	11i/Yes	2 LC GigE/2 RJ-45	Yes / Yes	16 / 64
Wide Area Network Interface Cards					

Configuration

2-port Programmable Serial Interface (PSI) X.25/Frame Relay/SDLC	J3525A	11.00 / No	RS 530, RS 232, V.35, RS 449 or X.21	Yes / Yes	16 / 32
Additional Interface Cards					
PCI 8 port Terminal Multiplexer	A6748A	11.00 / No	RS-232	Yes/No	16 / 128
PCI 64 port Terminal Multiplexer	A6749A	11.00 / No	RS-232 or RS-422	Yes/No	16/960
PCI Hyperfabric2 Fiber Adapter	A6386A	11.00 / No	LC Duplex	Yes / Yes	4 / 4
PCI Obsidian 2 USB Adapter	A6869B	11iv2/Yes		Yes / Yes	16/16

*NOTE: I/O Card is supported, but not orderable with system.

Supported Windows I/O Cards

I/O Card	Product Number	Special Notes	Connector Type(s)	Hot Plug / Factory Integration	Maximum Cards/Ports
Mass Storage Host Bus Adapters					
PCI Windows and Linux Ultra160 SCSI	A7059A ¹		VHDCI	Yes / Yes	8 / 8
PCI Windows Linux 2 port Ultra160 SCSI	A7060A ¹		VHDCI	Yes / Yes	8 / 16
Dual Channel Ultra320 SCSI Adapter	A7173A		VHDCI	Yes / Yes	8 / 16
PCI-X Smart Array P600 Serial Attached SCSI (SAS) Controller	337972-B21	External Storage Only	SFF8470	Yes/Yes	8/8 ²
PCI-X Smart Array 6402 128MB - factory integrated for a RAID 1 array	AB362A	Must order 2 identical HDDs in the hard partition	VHDCI	Yes / Yes	8 / 16
PCI-X Smart Array 6404 256-MB - factory integrated for a RAID 1 array	AB363A	Must order 2 identical HDDs in the hard partition	VHDCI	Yes / Yes	8 / 32
PCI-X 2 channel Smart Array 6402 128MB	A9890A		VHDCI	Yes / Yes	8 / 16
PCI-X 2 channel Smart Array 6404 256MB	A9891A		VHDCI	Yes / Yes	8 / 32
Emulex 4Gb PCI-X Fibre Channel HBA	AD167A		LC	Yes / Yes	12 / 12
Emulex 4Gb PCI-X Fibre Channel, Dual Channel HBA	AD168A		LC	Yes / Yes	8 / 16
PCI X 2 Gb/s Fibre Channel	AB232A ¹		LC	Yes / Yes	12 / 12
PCI X 2 channel 2 Gb/s Fibre Channel	AB466A		LC	Yes / Yes	8 / 16
PCI X 1 channel 2 Gb/s Fibre Channel	AB467A		LC	Yes / Yes	12 / 12
Local Area Network Interface Cards					
PCI 2 port Windows / Linux 1000Base-TX	A9990A		RJ-45	Yes / Yes	12 / 24
PCI 2 port Windows / Linux 1000Base-SX	A9899A		LC	Yes / Yes	12 / 24
PCI 1 port 1000BaseT	A7061A		RJ-45	Yes / Yes	12 / 12
PCI 1 port 1000BaseSX	A7073A		Duplex SC	Yes / Yes	12 / 12
Additional Interface Cards					
Graphics / USB Card (Optional)	A6869A	Max 1		No / Yes	2/ 2

Configuration

¹I/O card is supported, but not orderable with system.

²For Windows, each 337972-B21 external port supports a maximum of two (2) MSA50s attached in series.

Integrated Multifunction I/O

The HP Integrity rx8640 Server chassis supports either one or two Core I/O cards (AB314A). Core I/O slots are located along the right rear vertical edge of the chassis. One core I/O card is included with each system. The first core I/O card will support up to four cell boards in the server and all I/O slots. For support of two hard partitions, a second core I/O is required in the host system. For support of three or four hard partitions (nPars), a third and/or fourth core I/O card can be added in the rp84xx/rx86xx Server Expansion Unit. See its section for more details.

Each HP Integrity core I/O card provides the following features:

- **Management Processor:** The Management Processor (MP) is a dedicated processor that simplifies and extends system management, as well as, enhances serviceability. The MP feature set was designed to minimize/eliminate the need for the System Administrator to be physically at the system to perform tasks such as diagnostics, system management, or even hard resets.

Features:

- System management over the Internet or Intranet
- System console redirection
- Console mirroring
- System configuration for automatic restart
- Viewing history log of system events
- Viewing history log of console activity
- Setting MP inactivity timeout thresholds
- Remote system control
- Remote power cycle (except for MP housekeeping power)
- Viewing system status
- Event notification to system console, e mail, pager, and/or HP Response Centers
- Automatic hardware protection of critical environmental problems
- Access to management interface and console(s) on LAN failure (modem required)
- Auto system restart
- Remote resetting of hardware partitions
- Forward progress indicator (Virtual front panel)
- Out-of-band Manageability and PDC firmware update
- Configure manageability and console security
- SSL
- **External LAN port:** 1-GbE LAN port using an RJ 45 connector
- **External SCSI port:** Ultra3 LVD SCSI port for connections to mass storage or media
- **Access to internal peripheral bay:** Ultra320 SCSI port for connections to mass storage or media
- **Access to internal peripheral bay:** The first core I/O card enables half of the HP Integrity rx8640 Server peripheral bay, which includes one removable media and two low profile disks. The second core I/O card enables the remaining internal peripherals, two disks and one removable media bays. Customers that require access to more than two internal disks and/or one removable media slot must purchase the second core I/O card and more than one cell board.

The integrated multifunction I/O provides core I/O functionally and includes the Management Processor technology.

Configuration

Core I/O Loading Rules

- 1 Core I/O card is included with each HP Integrity rx8640 Server
- Load the first Core I/O board into slot 0.
- Core I/O slot 0 corresponds to Cell Board slot 0. Core I/O slot 1 corresponds to Cell Board slot 1.
- A cell board must be installed in slot 0 to enable use of Core I/O 0. Likewise, a cell board must be installed in slot 1 to enable use of Core I/O 1.
- Access to two internal disk drives and one Removable Media bay is enabled with the installation of the first Core I/O board.
- The optional second Core I/O board must be ordered to enable hardware partitioning (systems not using the Server Expansion Unit).
- The optional second Core I/O board must be ordered to enable access to the third/fourth internal disks and second removable media drive. (**NOTE:** For support of 3 or 4 hard partitions [nPartitions], a third and/or fourth core I/O board can be included in the rp84xx/rx86xx Server Expansion Unit. See its section for more details.)

Internal Disk Drives HP Integrity rx8640 Server supports up to four internal low profile hot plug disk drives.

Internal Disk Drive Specifications

Product Number	Disk Capacity	Rotational speed	Average seek time (read/write)	Sustained Bandwidth
AD146A	36 GB	15,000 RPM	3.6 msec (read); 3.9 msec (write)	40 MB/s
AD147A	73 GB	15,000 RPM	3.6 msec (read); 3.9 msec (write)	40 MB/s
AD148A	146 GB	10,000 RPM	4.7 msec (read); 5.2 msec (write)	40 MB/s
AD149A	300 GB	10,000 RPM	4.7 msec (read); 5.2 msec (write)	69 MB/s

For HP UX:

- Two UltraSCSI controllers provide each disk drive with an independent SCSI channel
- Supported by MirrorDisk/UX across disk drives, controllers, and Core I/O boards
- Must order two Core I/O cards to support more than two internal disk drives

For Windows:

- An rx8640 customer need only order AB362A OD1 in order to receive an SA6402 Smart Array card cabled and configured for RAID 1 mirroring in the factory. The AB362A product includes both the SA6402 Smart Array Card (A9890A) and the internal RAID cables (AB338A)..
- An rx8640 customer need only order AB363A OD1 in order to receive an SA6404 Smart Array card cabled and configured for RAID 1 mirroring in the factory. The AB363A product includes both the SA6404 Smart Array Card (A9891A) and the internal RAID cables (AB338A).
- The customer is limited to maximum of one AB362A or AB363A per partition.
- The customer may order additional Smart Array controllers as add in cards for connection to external storage devices. When these products are ordered with option OD1 they will be installed, but will not be connected to the internal HDDs. The supported Smart Array products (for external storage) on rx8640 are:
 - A9890A - SA6402
 - A9891A - SA6404
 - 337972-B21 - SA P600

Configuration

Internal Removable Media

- HP Integrity rx8640 Server contains two removable media bays, which will support either a DVD+RW or DAT drive. Removable media drives are not hot plug capable.
- DVD+RW drive provides enhanced features while preserving backward read compatibility with CD ROM. Data transfer rates of up to 6.75 MB/s are achieved with the DVD format; 4.8 MB/s can be achieved with the CD format. (**NOTE: Installing the Smart Array card connected to the internal drives does not affect the function of the DVD ROM.**)
- DAT 72-GB drive has a maximum storage capacity of 72 GB and is RoHS compliant.
- Must order two Core I/O cards to enable more than one Internal Media device.

Internal Removable Media Specifications

Product Number	Device	Capacity	Data transfer rate
AB351B*	DVD+RW (RoHS)		
AB400A	DAT-72	72 GB	

*NOTE: Third Party software (not included with AB351A) is required to support DVD write capability with Windows.

I/O Configuration Rules The following table summarizes previously mentioned configuration rules pertaining to usage of I/O slots and internal peripherals.

Configuration	Minimum Required Number of Cells	Minimum Number of Core I/Os
>8 I/O card slots	2	1
>2 Internal Disks	2	2
2 Internal Removable Media	2	2
2 Partitions	2	2

Additional I/O resources using the Server Expansion Unit (SEU)

Additional I/O resources can be obtained by adding the HP Server Expansion Unit (SEU). The SEU is an add on chassis containing I/O resources that complement the I/O and partitioning capabilities within the HP Integrity rx8620 Server. The SEU mirrors the I/O resources embedded within the HP Integrity rx8620 Server chassis, adding 16 I/O card slots, 4 disk bays, 2 removable media slots, and enabling 2 additional hard partitions.

The SEU must be installed in the same cabinet and directly above the host rx8640 server for factory racked installations. For field installations, the SEU can be installed in an adjacent rack at the same height as the server if there are space limitations. The preferred installation is directly above the host server in the same rack. Please refer to the Server Expansion Unit section in this guide or more specific details.

The following table summarizes the I/O configuration rules when an SEU is configured with the HP Integrity rx8640 Server.

Required Configuration	Minimum Required Number of Cells	Minimum Required Number of Core I/Os
>16 I/O card slots	3	4(1)
>24 I/O card slots	4	4(1)
>4 Disks	3	4(1)
>6 Disks	4	4(1)
3 Removable Media	3	4(1)
4 Removable Media	4	4(1)
3 Hard Partitions	3	4(1)
4 Hard Partitions	4	4(1)

Configuration

(1) Two Core I/O cards must be purchased and configured in each SEU

AC/DC Power

DC Power Supplies

The HP Integrity rx8640 Server supports up to six hot swap bulk power supplies for 2N+1 protection. The hot swap design allows for the replacement of a failed power supply without interrupting server operation. Two supplies are included with the base system. A minimum of one additional supply is required for each cell board. Following this rule, all configurations will have 2N+1 power protection.

PCI Power Supplies: PCI power supply is now a redundant N+1 design. One PCI power supply failure will not affect the I/O bay since the remaining PCI power supply will power both I/O bays (This is an upgrade from the sx1000 based systems). PCI power supplies are not hot swap capable.

AC Power

The HP Integrity rx8640 Server contains four C20 power receptacle ports located at the bottom rear bulkhead. A minimum of two power cords must be used to maintain normal operation of the HP Integrity rx8640 Server. A second set of two cords can be added to improve system availability by protecting, for example, against power grid failures or accidentally tripped circuit breakers. The HP Integrity rx8640 Server hardware is capable of receiving AC input from two different AC power sources. The objective is to maintain full equipment functionality when operating from power source A and power source B, or A alone, or B alone. This capability is called "fault tolerant power compliance".

Although many HP Integrity rx8640 Server configurations can be sufficiently powered from a single 16 /20 amp branch circuit, strongly recommends using one 16 amp (minimum) branch circuit per power cord. Due to the variety of 16/20 plugs used throughout the world, the HP Integrity rx8640 Server menu offers a choice of plug options.

All HP Integrity rx8620 32 servers are shipped with four AC power cords.

AC Power Consumption

The HP Integrity rx8640 Server power consumption will vary greatly depending on the hardware configuration and the input line voltages supplied at customer sites. Because of the disparity of line voltages throughout the world it's best to represent power consumption in VA (Volt Amperes). With power consumption being of high concern throughout the world, it's necessary to specify consumption in a couple of different ways. First, the "Marked Electrical" number will represent the maximum wattage of a given configuration. This is the number that electricians typically use to size an electrical connection. It is also the number that is provided on the label of the server . . . Second, the "Typical" number will represent the expected power consumption of a given configuration. The specified "typical" number is the approximate power consumption that a customer will most likely experience, and could be used for power budgeting purposes.

Configuration

Configuration

HP Integrity rx8640 Server Fully Loaded Configuration

- Sixteen 1.6 GHz Intel Itanium 2 processors
- 256 GB of Memory
- 16 PCI cards
- 4 cell boards
- 4 internal hard drives
- 2 DVD drives
- 2 Core I/O cards
- 6 bulk power supplies.
- Typical power consumption: 3962 VA (19.81 A @ 200 VAC across 2 cords)
- Marked Electrical for the server: 5400 VA (30A @ 180 VAC across 2 cords)
- Marked Electrical per line cord: 2700 VA (15A @ 180 VAC across each cord)

HP Integrity rx8640 Server Average Configuration

- Eight 1.6 GHz Intel Itanium 2 processors
- 16 GB of Memory
- 8 PCI cards
- 2 cell boards
- 2 internal hard drives
- 1 DVD drives
- 2 Core I/O cards
- 3 bulk power supplies.
- Typical power consumption: 1870 VA (9.35 A @ 200 VAC across 2 cords)

Power Distribution Units **60 amp Power Distribution Unit-E7683A (US) and E7684A (International)**

A 60 amp Power Distribution Unit (PDU) has been developed for Integrity customers that prefer to use fewer, higher amperage connections into their wall electrical infrastructure. The drawing below shows the PDU layout. The PDU is designed to fit horizontally in standard 19 inch cabinets and consumes 3 EIA units of racking space. This PDU is sold separately and can be ordered with any Server solution.

Each 60-amp PDU contains eight C19 outlets spread evenly among four 20 amp branch circuits (two C19s per branch). Each of the four branch circuits is protected by a circuit breaker that is either 20 amp (United States) or 16 amp (International). All 60-amp PDUs are delivered with an IEC 309 63A plug.

The drawing below is an example of how the PDU can be configured with the HP Integrity rx8640 Server. In this case there are two HP Integrity rx8640 servers (average configurations drawing ~9 amps each) and two 60-amp PDUs configured with redundant power. The blue cords represent the primary power connections needed for normal operation. In this example, cords from each server are plugged into a separate branch circuits. However, it is acceptable, for lower VA configurations, for each server to plug both grid A cords into one branch circuit and both grid B cords into second branch circuit. The remaining PDU outlets can be used to power other components as long as the 16/20 amps per circuit breaker and 60 amps per PDU rating is not exceeded.

For redundant power inputs, the second set of red cords is added. If the second PDU is plugged into a second grid this configuration provides protection against:

- Losing power from a single power grid
- Accidental tripping of one or two circuit breakers
- Accidental disconnect of a single PDU power cord
- Accidental disconnect of up to four system power cords

Configuration

30-amp Power Distribution Unit-Factory-integrated A5499AZ opt. 001 (US) and 002 (International), or Field integrated E7681A (North America) and E7682A (International)

A 30 amp Power Distribution Unit (PDU) is also supported with HP Integrity rx8640 Server. The PDU is designed to fit horizontally in standard 19 inch cabinets and consumes 3 EIA units of racking space. This PDU is sold separately and can be ordered with any Server solution.

Each 30 amp PDU contains two C19 and eight C13 outlets spread evenly between two 20 amp branch circuits. Unlike the 60 amp PDU, each 30 amp PDU can only support one HP Integrity rx8640 Server. The following configuration guidelines apply when using the 30 amp PDU:

- HP Integrity rx8640 Server plugs A0 and A1 should be plugged into the same PDU
- Ax and Bx cords should never be plugged into the same PDU
- Use two 30 amp PDUs to achieve input power redundancy. A0/A1 and B0/B1 into separate PDUs.
- If two HP Integrity rx8640 servers share a single 2 meter cabinet, 30 amp PDUs cannot provide redundant input power due to lack of cabinet space (4 PDUs would need 8 EIA units of space). For this situation, use 60 amp PDUs.
- Ordering tools will not force the purchase of a second PDU for input power redundancy. A second PDU must be manually selected if redundant input power is desired.

Partitioning

A hardware partition corresponds roughly to a single, standalone system. The HP Integrity rx8640 Server can be subdivided into four partitions, each containing one or more cells that communicates coherently over a high bandwidth, low latency crossbar fabric. Cells are grouped into physical structures called cabinets or nodes. Special programmable hardware in the cells defines the boundaries of a partition in such a way that the isolation is enforced from the actions of other partitions. Each partition runs its own independent instance of the operating system (HP UX 11i v2, Windows 2003 Data Center Edition, or Windows 2003 Enterprise Edition). Applications cannot span partitions since each partition runs its own instance of the OS, essentially functioning as a stand alone server. However, different partitions may be executing the same or different revisions of an operating system, or they may be executing different operating systems altogether (such as HP UX 11i v2, Windows 2003 Data Center Edition, or Windows 2003 Enterprise Edition), with OS availability.

Each partition has its own independent processors, memory and I/O resources consisting of the resources of the cells that make up the partition. Resources may be removed from one partition and added to another without having to physically manipulate the hardware just by using commands that are part of the System Management interface. With future releases of HP UX and Windows, using the related capabilities of dynamic reconfiguration (e.g. on line addition, on line removal), new resources may be added to a partition and failed modules may be removed and replaced while the partition continues in operation.

Partitioning the resources of the complex in this way makes it easy to run multiple applications on the same physical system; you can allocate physical resources and tune the operating system running on each partition depending on the needs of the application (or the most important application) you intend to run on it. Alternatively, you can configure the HP Integrity rx8640 Server as a single partition, allowing all the resources to be focused on a single set of tasks, for example a large online transaction processing application.

You can increase or reduce the processing power of a partition by adding or deleting cells. With HP UX 11i v2, you must shut down the operating system running on the affected partition(s) before moving cells, and before making configuration changes that will take effect. Though HP UX 11i v2 does include commands for some configuration tasks, recommends you use the Partition Manager (parmgr) to configure partitions.

Hardware based partition configuration changes may require a reboot of the HP UX partition depending upon the configuration change. The reboot of the partition only affects the partition that is being

Configuration

reconfigured. The other partitions defined in the chassis are not affected and will continue to execute without interruption. In a future HP UX release, dynamic hard partitions will be supported. Dynamic partitions imply that partition configuration changes do not require a reboot of the partition.

The HP Integrity rx8640 Server can be divided into four independent hardware partitions when configured with the Server Expansion Unit. In a partitioned configuration, I/O bay resources such as I/O slots, core I/O, disk and removable media bays, are always dedicated to the corresponding cell board slot. In other words, I/O bay 0 resources are always configured to the cell board in Cell slot 0. Therefore, in a partitioned system, the amount of resources within a partition is always proportional to the number of cells within that partition. There is no flexibility to otherwise divide these components. For example, in a system configured with two cells in separate nPars, it is not possible to include twelve I/O slots in partition 0 and four I/O slots in partition 1. Please refer to the "Server Expansion Unit" section in this guide or more specific details.

The table below summarizes the resource availability based on hardware partitions.

Number of Hard Partitions	Minimum Number of Cells	Minimum Available I/O slots	Core I/O (Required)	Minimum Available Disk/Media Bays
1 Partition	Any one cell	8	1	2/1
2 Partitions	Any two cells	16	2	4/2
3 Partitions	Any three cells	24	4	6/3
4 Partitions	Four cells	32	4	8/4

HP Integrity rx8640 servers support virtual partitioning (vPars) to the single processor level with a new release of HP UX similar to support on 9000 servers with HP UX 11i v1. With vPars, a user will be able to support up to eight separate virtual partitions each with an instance of HP UX within each hard partition. vPars will provide many of the features of nPars but without the electrical isolation and support for hardware failures that nPars provides.

System Management Software Features

Central Point of Administration for HP UX and Windows

Systems Insight Manager is an easy to use multi system management solution with web enabled and command line interfaces. Systems Insight Manager delivers multi system access to all key system administration tools for fault monitoring, configuration, and workload management. Systems Insight Manager will replace Servicecontrol Manager. It is available for download from the web now and will be included in the box soon. Systems Insight Manager integrates with many other HP UX specific system management tools, including the following:

HP-UX

Software Deployment

- Ignite UX-Ignite-UX addresses the need for HP-UX system administrators to perform fast deployment for one or many servers. It provides the means for creating and reusing standard system configurations, enables replication of systems, permits post installation customizations, and is capable of both interactive and unattended operating modes.
- Software Distributor (SD-UX) is the HP-UX administration tool set used to deliver and maintain HP-UX operating systems and layered software applications. Delivered as part of HP-UX, SD-UX can help you manage your HP-UX operating system, patches, and application software.
- Update UX is a tool for customizing the behavior and automating the process for HP-UX Operating Environment updates.
- Software Package Builder is an intuitive, GUI based tool for packaging software into SD-UX packages so that they can be installed and managed in the same way as HP's system software.

Configuration

Configuration

- System Administration Manager (SAM) is used to manage accounts for users and groups, perform auditing and security, and handle disk and file system management and peripheral device management. HP Systems Insight Manager enables these tasks to be distributed to multiple systems and delegated using role based security.
- HP-UX Kernel Configuration allows users to tune both dynamic and static kernel parameters quickly and easily from a Web-based GUI to optimize system performance. This tool also sets kernel parameter alarms that notify you when system usage levels exceed thresholds.
- Partition Manager creates and manages nPartitions-hard partitions for high end servers. Once the partitions are created, the systems running on those partitions can be managed consistently with all the other tools integrated into HP Systems Insight Manager. See "partitioning" for more information.
- HP-UX webmin-based Admin is a Web based system management framework that allows a wide variety of open source webmin system management modules to be plugged in. HP supports this tool for the configuration of the HP- UX Apache-based Web Server and the HP-UX Tomcat-based Servlet Engine.
- HP-UX Bastille is a security hardening/lockdown tool that enhances the security of an HP-UX UNIX® host. It accommodates the various degrees of hardening required of servers used for webs, applications, and databases.
- Security Patch Check performs analysis of file sets and patches installed on an HP-UX system and generates a report of recommended security patches. Use of the Security Patch Check software tool can help efficiently improve system security.
- Event Monitoring Service (EMS) keeps the administrator of multiple systems aware of system operation throughout the cluster, and notifies the administrator of potential hardware or software problems before they occur. HP Systems Insight Manager can launch the EMS interface and configure EMS monitors for any node or node group that belongs to the cluster, resulting in increased reliability and reduced downtime.

Workload Management for HP-UX

- Process Resource Manager (PRM) controls the resources that processes use during peak system load. PRM can manage the allocation of processor, memory resources, and disk bandwidth. It allows administrators to run multiple mission-critical applications on a single system, improve response time for critical users and applications, allocate resources on shared servers based on departmental budget contributions, provide applications with total resource isolation, and dynamically change configuration at any time-even under load. (fee-based)
- HP-UX Workload Manager (WLM) A key differentiator in the HP-UX family of management tools, Workload Manager provides automatic processor resource allocation and application performance management based on prioritized service level objectives (SLOs). In addition, WLM allows administrators to set real memory and disk bandwidth entitlements (guaranteed minimums) to fixed levels in the configuration. The use of workload groups and SLOs improves response time for critical users, allows system consolidation, and helps manage user expectations for performance. (Fee-based)

OpenView for HP-UX

- OpenView Operations Agent-collects and correlates OS and application events (fee-based)
- OpenView Performance Agent-determines OS and application performance trends (fee-based)
- OpenView GlancePlus-shows real time OS and application availability and performance data to diagnose problems (fee-based)
- OpenView Data Protector (Omniback II)-backs up and recovers data (fee-based)

Windows

Configuration

System Management for Windows

HP Integrity Essentials Foundation Pack for Windows includes:

- Systems Insight Manager (see above).
- Smart Setup CD includes an Extensible Firmware Interface (EFI) based setup utility (EBSU) designed for easy server configuration and array controller configuration. The DVD also includes all the latest tested and compatible HP drivers, HP firmware, HP utilities, and HP management agents that assist both in the server deployment process by preparing the server for installation of the Windows operating system and in the ongoing management of the server. If you are interested in even easier deployment, HP suggests you order your Integrity server preloaded with Windows Server 2003.
- Partition Manager and Partition Commands create and manage nPartitions-hard partitions for high end servers. Once the partitions are created, the systems running on those partitions can be managed consistently with all the other server management tools available for Windows servers.
- System Management Homepage for Integrity servers with Windows provides consolidated information about the system health and configuration through a simple, Web based user interface. All system faults and major subsystem status are reported within the System Management Homepage, which is accessible either directly through a browser or through a management application such as Systems Insight Manager or an enterprise management application (available on select systems).

OpenView for Windows

- OpenView Operations Agent-collects and correlates OS and application events (fee-based)
- OpenView Performance Agent-determines OS and application performance trends (fee-based)
- OpenView Data Protector (Omniback II)-backs up and recovers data (fee-based)

Instant Capacity (iCAP, formerly known as Instant Capacity on Demand [iCOD])-For HP UX only (Windows is currently not supported)

Racking

The HP Integrity rx8640 Server was designed to provide industry leading performance density and availability when ordered in a racked configuration. At 17 EIA units (29.75 inches), two HP Integrity rx8640 servers can be mounted into a single rack two meter cabinet with 7 or 8 EIA units of extra space for mounting external peripherals. One rx8640 can be mounted in a rack along with a Server Expansion Unit.

The HP Integrity rx8640 Server industrial design and packaging was designed to allow easy and quick access to all of the system's components. The most frequently handled devices, removable media and disks, are directly accessible at the system's front. By removing the front bezel, hot swap fans, hot swap power supplies, and PCI power supplies can be completely serviced. At the rear, core I/O and more hot swap fans are directly accessible. For access to all other components, the rack mounted HP Integrity rx8640 Server comes with rack sliders.

These rack sliders enables the HP Integrity rx8640 Server to be slid forward out of the Rack cabinet for servicing of internal components such as fans, cell boards, and I/O cards, while the system is still running. The sliders also allows for servicing or replacement of any FRU (field replaceable unit) without removing the chassis from the cabinet. The HP Integrity rx8640 Server industrial design and slider strategy enables access and removal of any FRU within 15 minutes or less. This design feature minimizes the downtime associated with system upgrades in the rare event of a component failure. Also included with ever rack mounted HP Integrity rx8640 Server is a cable management arm (CMA). The CMA neatly secures data cables and prevents cables from becoming entangled while servicing of the system.

The following racking rules apply for HP Integrity rx8640 servers configured with an Server Expansion

Configuration

Unit.

- The Server Expansion Unit 2 must be mounted in the same cabinet as the host HP Integrity rx8640 Server
- The HP Integrity rx8640 Server must be mounted directly below the Server Expansion Unit

Ballasts for Rack System E cabinets (not used with Universal rack 10K G2) Due to the weight of the HP Integrity rx8640 Server, ballast kits have been developed to add stability to Rack Systems/E cabinets while the system is being serviced. Every HP Integrity rx8640 Server shipped to customers will be shipped with a ballast kit. These ballasts were designed to easily attach to the rear anti tip foot that comes standard with every Rack System E cabinet. Use of the HP Integrity rx8640 Server ballast kit is mandatory and should be installed immediately.

Heavy Duty Stabilizing Kit for 10K G2 Universal rack (not used with Rack System E) A heavy duty stabilizing kit is required for the rack of the rx8640 server to add stability for the Universal 10K G2 rack. With this stabilizing kit, the ballast is no longer needed with the new Universal rack. Use of the Heavy Duty Stabilizing kit is mandatory and should be installed immediately.

UPS Management of local UPSs for the rx7640 and rx8640 is now through a LAN port on the core I/O card. Management of UPSs by the predecessor, rx7620 and rx8620 servers was through a serial port on the core I/O. The serial port is not available on the rx7640 and rx8640 servers. Therefore, when upgrading or adding rx7640 and rx8640 servers to your environment and using local UPSs (as opposed to datacenter wide UPSs), make sure there is a LAN management card available on the local UPS.

10000 and 9000 Racks The 9000 and Integrity servers are supported for field installs into these racks. Factory integration is not yet supported for 10000 and 9000 racks. Differing depth requirements of the 9000/Integrity racking kits preclude racking 9000/Integrity servers and ProLiant servers in the same racks.

For further details, refer to the racking solutions section in the configuration guide.

Third-Party Racking Servers are designed to maximize performance density when installed into Rack Systems. Rack Solutions maintain the high level of safety and reliability of Server solutions that customers have come to expect. Although strongly recommends racking servers in Rack Solutions, it is recognizes that some customer circumstances may prohibit this. For those customers, has developed a set of guidelines that when followed, enables server installations into third party cabinets. It is extremely important that the guidelines be followed due to the wide variety of cabinets in the market place.

Upgrades

HP Integrity rx86xx/9000 rp84xx Upgrades to HP Integrity rx8640 Servers All HP rp84xx, rx84xx servers are upgradeable to rx8640 servers in the current chassis.

Included in Upgrade Kit (AD056A):

System Backplane

The Kona System backplane is a new design with the following feature modifications:

- New high speed differential links
- Redesign of the crossbar ASIC
- Additional switch fabric on the backplane
- Redesign of the backplane power subsystem
- Redesign of the system clock infrastructure
- New high speed, impedance controlled, board-to-board connectors will be used

Mass Storage Backplane PCA

- The mass storage subsystem upgrades from SCSI SE interconnect to U320.

PCIX IO Backplane

- PCI-X 2.0 (266MHz) based I/O attach

Other Miscellaneous .

Nameplates and Labels

Read Me Docs, Upgrade Guide, CDROM

Misc Cables

Must Order Separately:

CPU Modules

(Unless already have Madison CPU modules)

Cell Boards

- New Cell board design to support new chipset and future Itanium CPUs

Memory DIMMs

- The memory system uses Double Data Rate DRAMs (DDR II).

Core IO

- U320 support

Reuse:

Chassis

System Fans

AC Power Distr PCA

DC Power Distr PCA

OL* PCA (IO cards)

Bulk Power Supplies

Hard Disk Drives

Removable Media Drives

Supported IO Cards (please refer to supported I/O card list)

Technical Specifications

Server model number rx8640

Server product numbers	Base	AB297A
	Number of processor cores	2-16
	Hardware Warranty	1 year same day on site

Fast Bundles (All include base chassis and power supplies)	Product Number	Number of Processors	Number of Cell Boards	Number of core I/O Cards	Number of Power Supplies
	AD065A	2	1	1	3
	AB442A	4	1	1	3
	AB443A	8	2	1	4
	AB444A	16	4	2	6

Supported Processors	1.6-GHz Intel Itanium 2 processor	Cache Floating Point Coprocessor	6 MB Yes
----------------------	-----------------------------------	----------------------------------	----------

Memory	Memory slots	64 (16 per cell board)
	Minimum memory (pair: 2 DIMMs)	2 GB
	Maximum memory capacity	128 GB (32 GB per cell board)

Internal Disks	Maximum disk mechanisms	4
	Maximum disk capacity	1.2 TB
	Maximum disk capacity (8 mechanisms with SEU)	2.4 TB
	Internal removable media	2 slots
	Internal removable media (with SEU)	4 slots
	DVD+RW (2 additional slots with SEU)	2 slots
	DAT-72 GB	

Technical Specifications

Core I/O	Ultra320 SCSI-LVD	1
	1 GbE (RJ 45 connector)	1
	RS-232 serial port (one console)	1
	100Base-T port (LAN console connection)	1

I/O Buses and Slots	Total hot plug PCI X Slots	16
	(266 MHz; 64 bits)	
	8 Dual channel slots (2128 MB/s each)	
	6 Dual-channel slots (1060 MB/s each)	
	2 Single channel (530 MB/s each)	

Maximum I/O Cards (See supported I/O table for specific products)	Mass Storage	8-16
	LAN	2-16
	WAN	16
	Multi-Function (Mass Storage / LAN)	14-16
	Additional Interface Cards	4-16

Electrical Characteristics	AC Input power	200-240V 50/60 Hz
	Hot swap Power supplies	6 total, 2 included with base
	Redundant AC power inputs	2 required, 4 cords for 2N
	Typical Power dissipation (VA) for Maximum processor, Memory, disk, I/O configurations	3800 VA 19.5A @200VAC
	Maximum Power dissipation (VA)*	5400 VA, 27A @200VAC
	Power factor at full load	0.98 (approximately)
	kW rating for UPS loading*	6.0

*NOTE: Represents theoretical maximum power/heat dissipation under worst case conditions, may increase with future upgrades

Technical Specifications

Site Preparation	Site planning and installation included	Yes
	Depth (in/mm)	30 in (762 mm)
	Width (in/mm)	19 in (482 mm)
	Height (in/mm/EIA) Racked	29.75 in (755 mm)/17 units
	Height (in/mm) Pedestal	32.8 in (833 mm)
	Weight (lbs/kg)	378 lbs (168 kg)

Environmental Characteristics	Acoustics (sound power) at 7.2 Bels LwA 25°C	
	Acoustics (sound power) at 7.5 Bels LwA 30°C	
	Acoustics (operator/bystander) at 24°C	61.0 dB LpA
	Operating Temperature (up to 5000 ft)*	41° to 95° F (5° to 35° C)
	Non-operating Temperature	-40° to 158° F (-40° to 70° C)
	Maximum rate of temperature change	68° F (20° C)/hour
	Operating relative humidity	15% to 80%, non-condensing, max. web bulb = 78.8° F (26° C)
	Non-operating relative humidity	5% to 90%, non-condensing
	Operating altitude above sea level	To 10,000 feet (3.0 km)
Non-operating altitude above sea level	To 15,000 feet (4.5 km)	

*NOTE: Maximum operating temperature range up to 1524 meters (5000 feet.) For higher altitudes, derate the maximum temperature by 1°C/350 meters (1000 feet) above 1524 meters (5000 feet).

Regulatory Compliance	Regulatory Model Number	
	Electromagnetic Interference	Complies with FCC Rules and Regulations, Part 15, as a Class A digital device. Manufacturer's Declaration to EN55022 Level A, VCCI Registered, Class 1, Korea RLL
	Safety	UL Listed, cUL Certified, compliant with EN 60950

Technical Specifications

© Copyright 2003-2006 Hewlett-Packard Development Company, L.P.

The information contained herein is subject to change without notice.

Intel and Itanium are registered trademarks or trademarks of Intel Corporation in the U.S. and/or other countries.

The only warranties for HP products and services are set forth in the express warranty statements accompanying such products and services. Nothing herein should be construed as constituting an additional warranty. HP shall not be liable for technical or editorial errors or omissions contained herein.